

Features & Specifications of K-FORM Screed Rails

- Enables adjoining bays to be poured simultaneously.
- 'Click-together' ease
- Pre-drilled holes for dowel bars
- Pre-drilled holes in base for anchoring
- Manufactured in durable 100% recycled uPVC
- Removable top strip to allow joint sealing
- No removal after use
- Designed for pours of 100mm-225mm thick

Cross Section of K-FORM

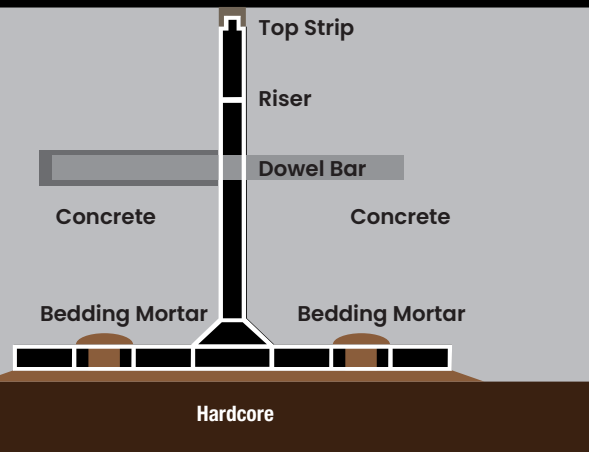

K-FORM

Concrete Formwork Systems

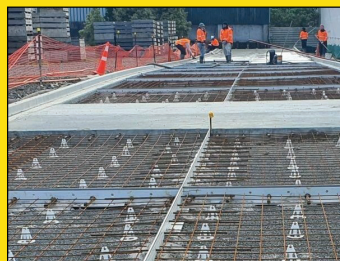
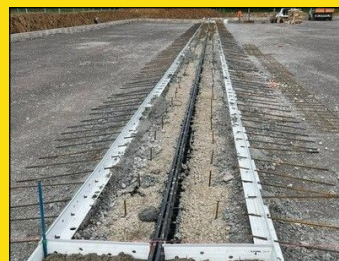
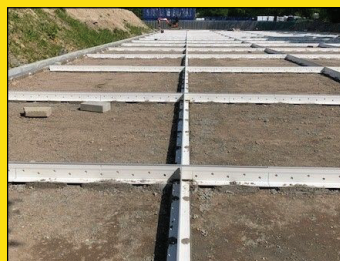

Visit our website for more information
about K-Form



K-FORM

Concrete Formwork Systems

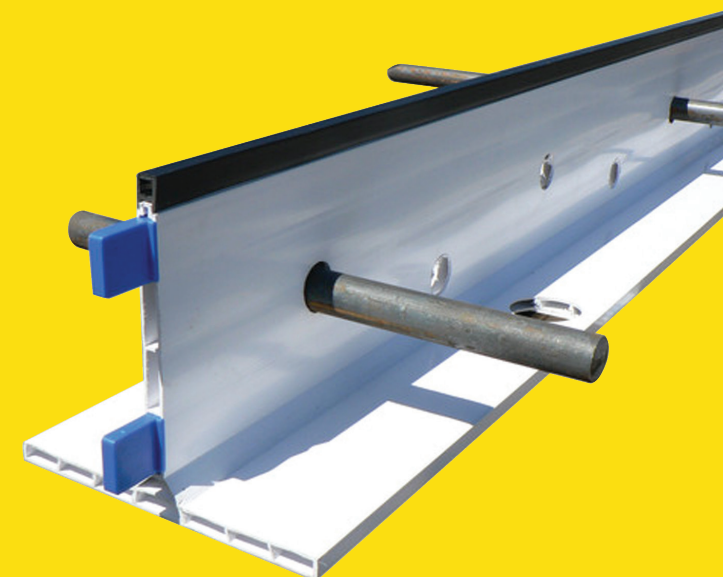

**The Innovative Recycled
Time & Money Saving
uPVC Sacrificial
Screed Rail System**



kform.co.uk
Work smarter not harder

kform.co.uk
Work smarter not harder

kform.co.uk
Work smarter not harder

About K-FORM Screed Rails

K-FORM UPVC Screed Railing provides the construction industry with an economical, efficient and environmentally friendly alternative to steel and timber formwork.

Made from 100% recycled materials, K-FORM is lightweight, durable and does not require removal after placement of concrete. It is easily cut to length on site and has pre-drilled holes in the vertical face for placing steel dowels bars and in the base for anchoring. K-FORM's patented design features a removable top strip for joint sealing and its unique end clips allow for quick and easy installation.

Intended to be used with all types of screeds including; twin beams, Roller Strikers and Vibro Strikers, etc. K-FORM's K135 and K85 sacrificial railing replaces steel forms where joints are needed.

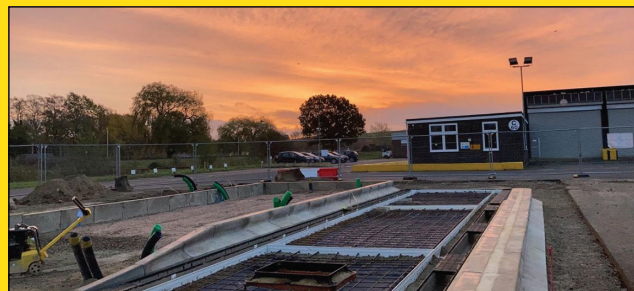

K-FORM K135 Screed Rail for Slab thickness 150mm - 225mm

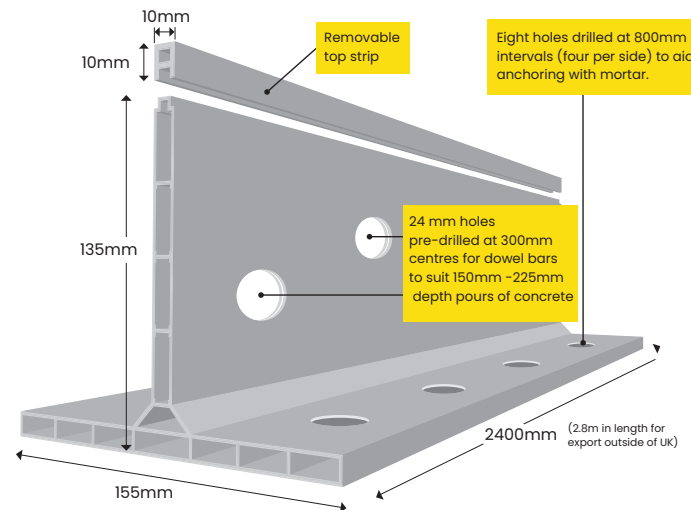

K-FORM Screed Rail Top Strip Angle Joint

Top Strip Angle Joints integrate seamlessly with K-FORM K85 and K135 Screed Rails. They provide a clean and tidy joint detail at intersections and should be used when it is intended to leave the topstrip in place after pouring.

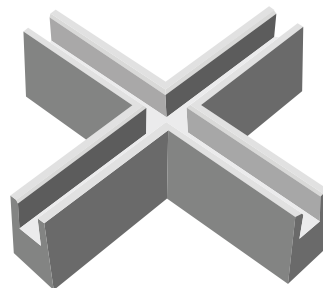

K-FORM K85 Screed Rail for Slab thickness 100mm - 140mm

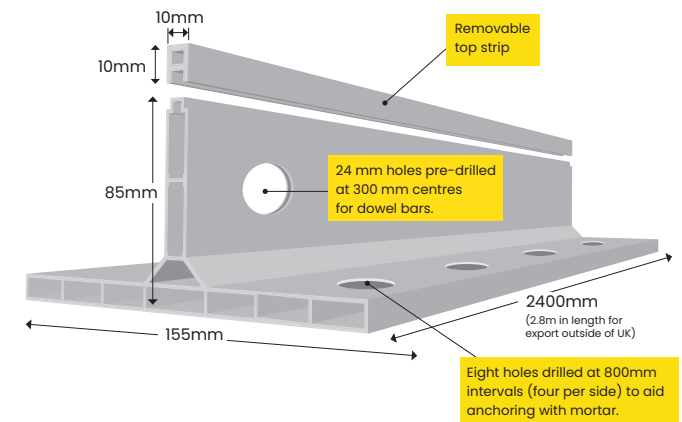

K-FORM Screed Rail 25mm Extension Strip

- Allows increase in height of 25mm
- Integrates seamlessly with K-FORM Screed Rails
- Compatible with K-FORM top strip
- Fast and easy clip on design

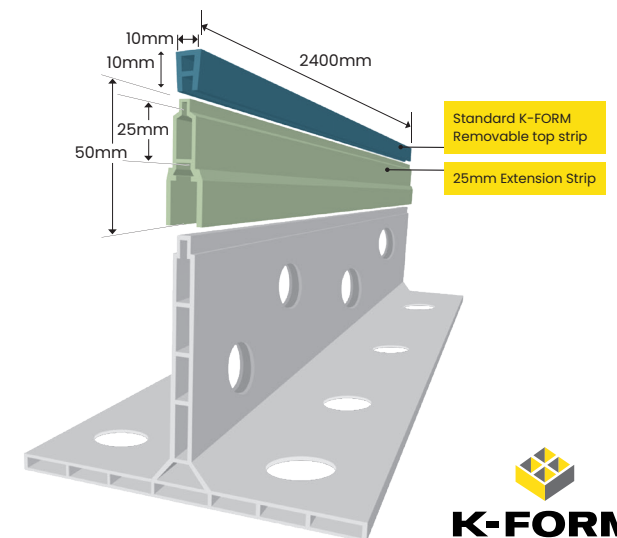

enquiries@kform.co.uk

kform.co.uk

Telephone Enquiries: (0) 1656 746071